

3/4-10 UNC - 2B  $\nabla$  .75 [19.1]  
THIS IS A LIFTING HOLE FOR CYLINDER HEAD (MAINTENANCE) ONLY.  
DO NOT USE THIS HOLE FOR LIFTING COMPRESSOR!

$\square$   $\phi$  1.25 [31.8]  $\nabla$  .05  
FLAT CREATED FOR MOUNTING ACCELEROMETER  
CENTERED ON LIFTING HOLE

[1079.5] 42.50 CLEARANCE REQUIRED  
TO REMOVE ROTOR BLADES  
[190.5] 7.50 CLEARANCE REQUIRED  
TO REMOVE END COVER  
AND CYLINDER HEAD

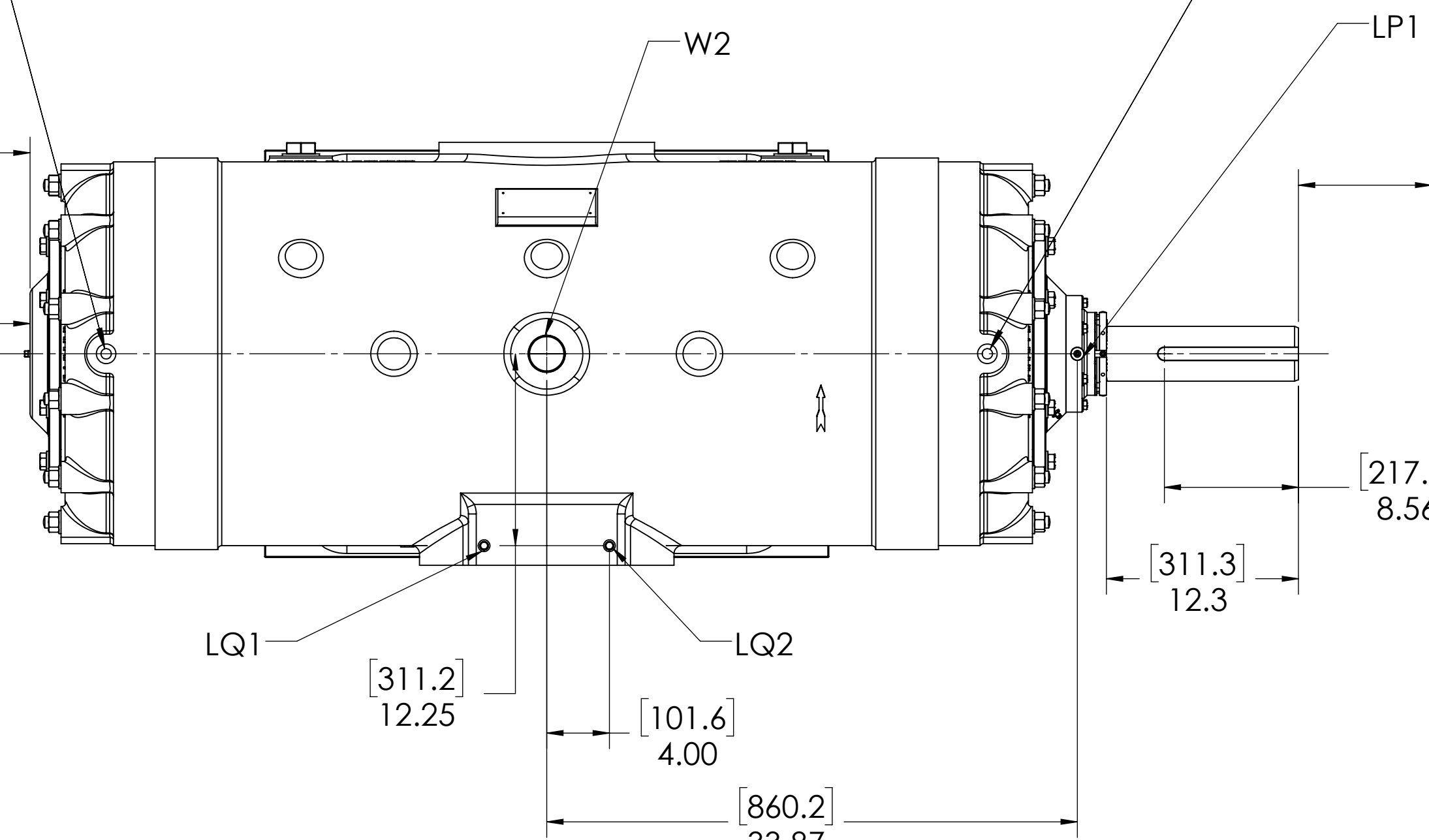

3/4-10 UNC - 2B  $\nabla$  .75 [19.1]  
THIS IS A LIFTING HOLE FOR CYLINDER HEAD (MAINTENANCE) ONLY.  
DO NOT USE THIS HOLE FOR LIFTING COMPRESSOR!

$\square$   $\phi$  1.25 [31.8]  $\nabla$  .05  
FLATA CREATED FOR MOUNTING ACCELEROMETER  
CENTERED ON LIFTING HOLE

[215.9] 8.50 CLEARANCE REQUIRED  
TO REMOVE CYLINDER HEAD AND  
SEAL ADAPTER

[22.23]  $^{+0.08}$ <sub>0</sub>  
[.875]  $^{+0.003}$ <sub>-.000</sub> KEYWAY

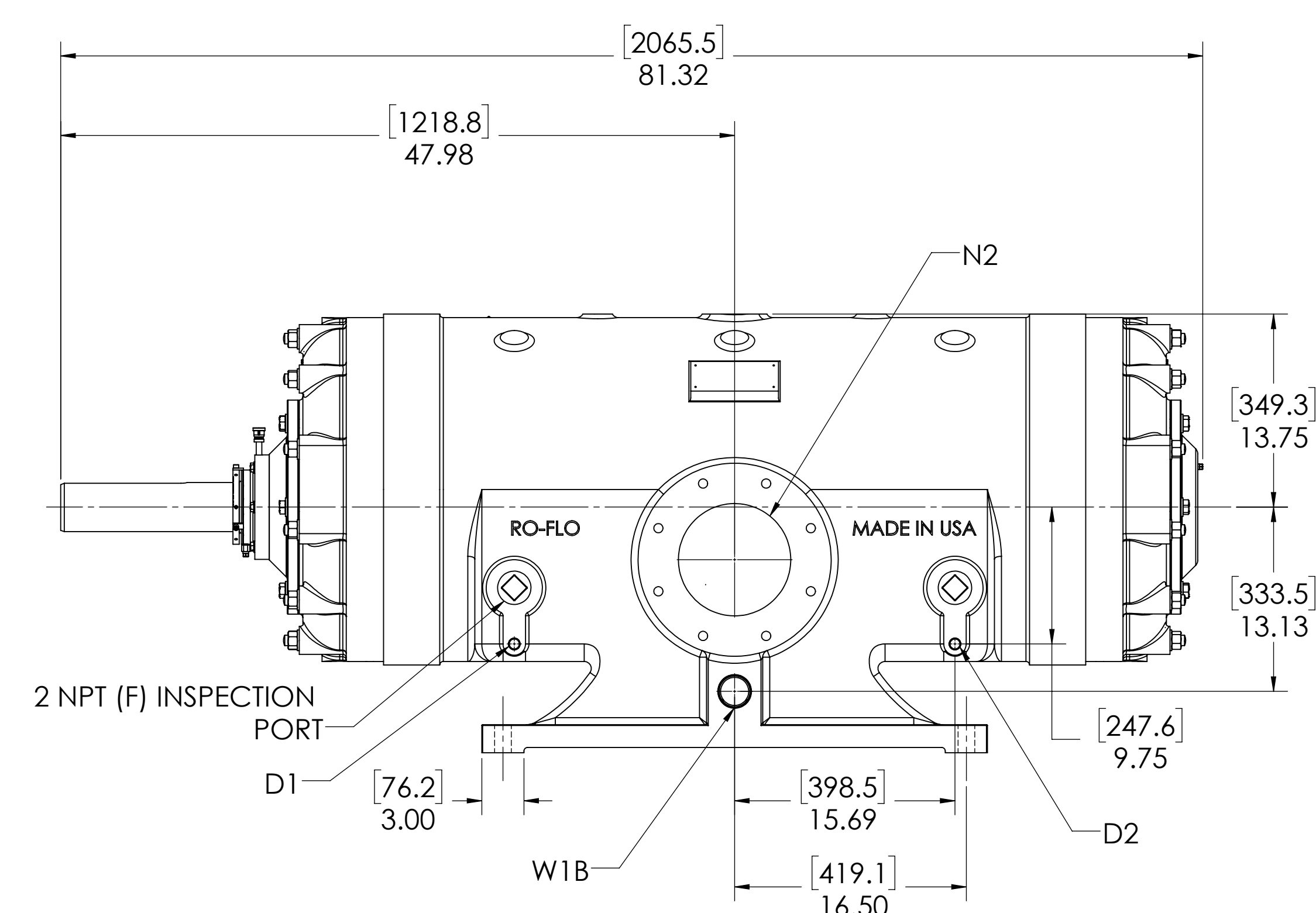
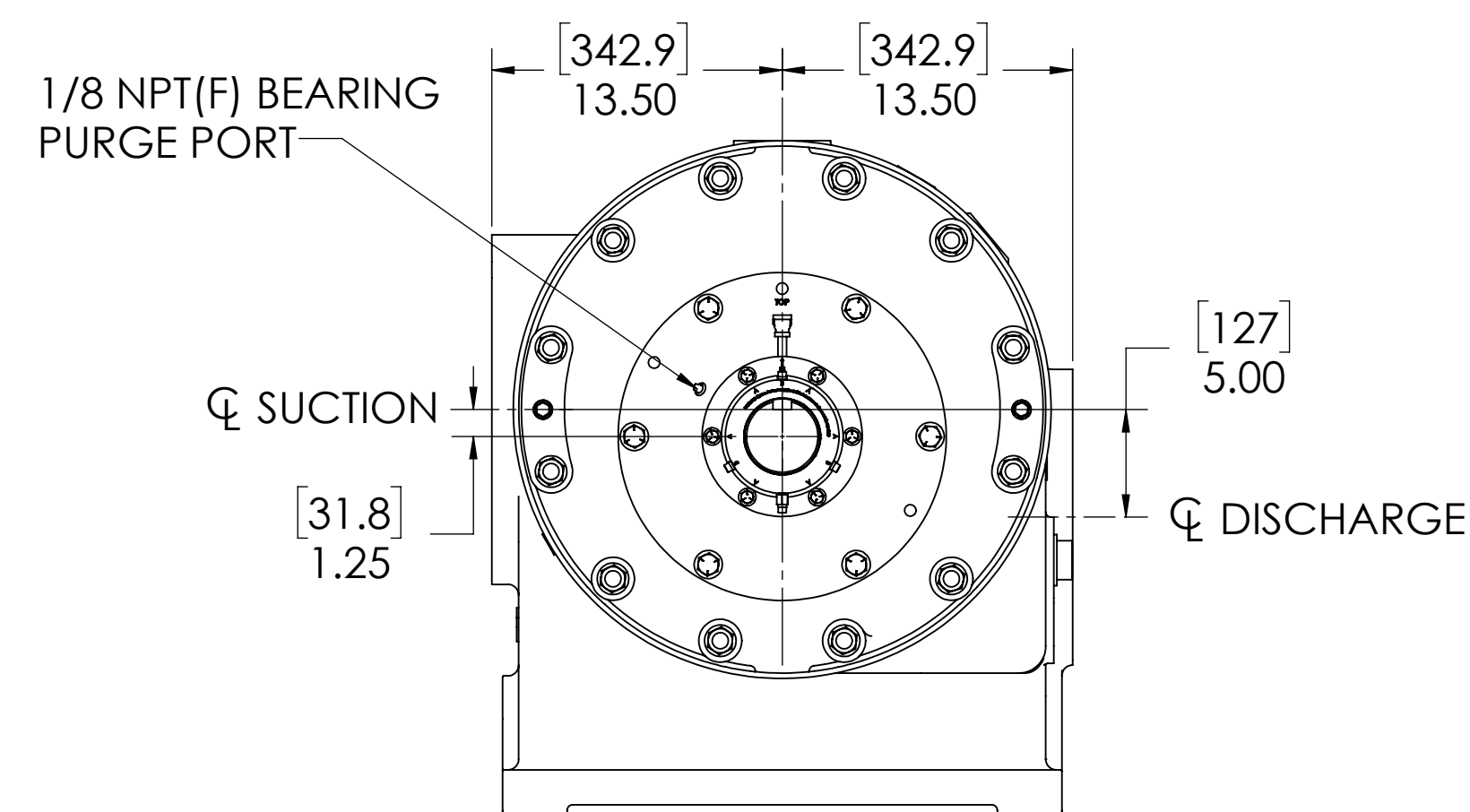
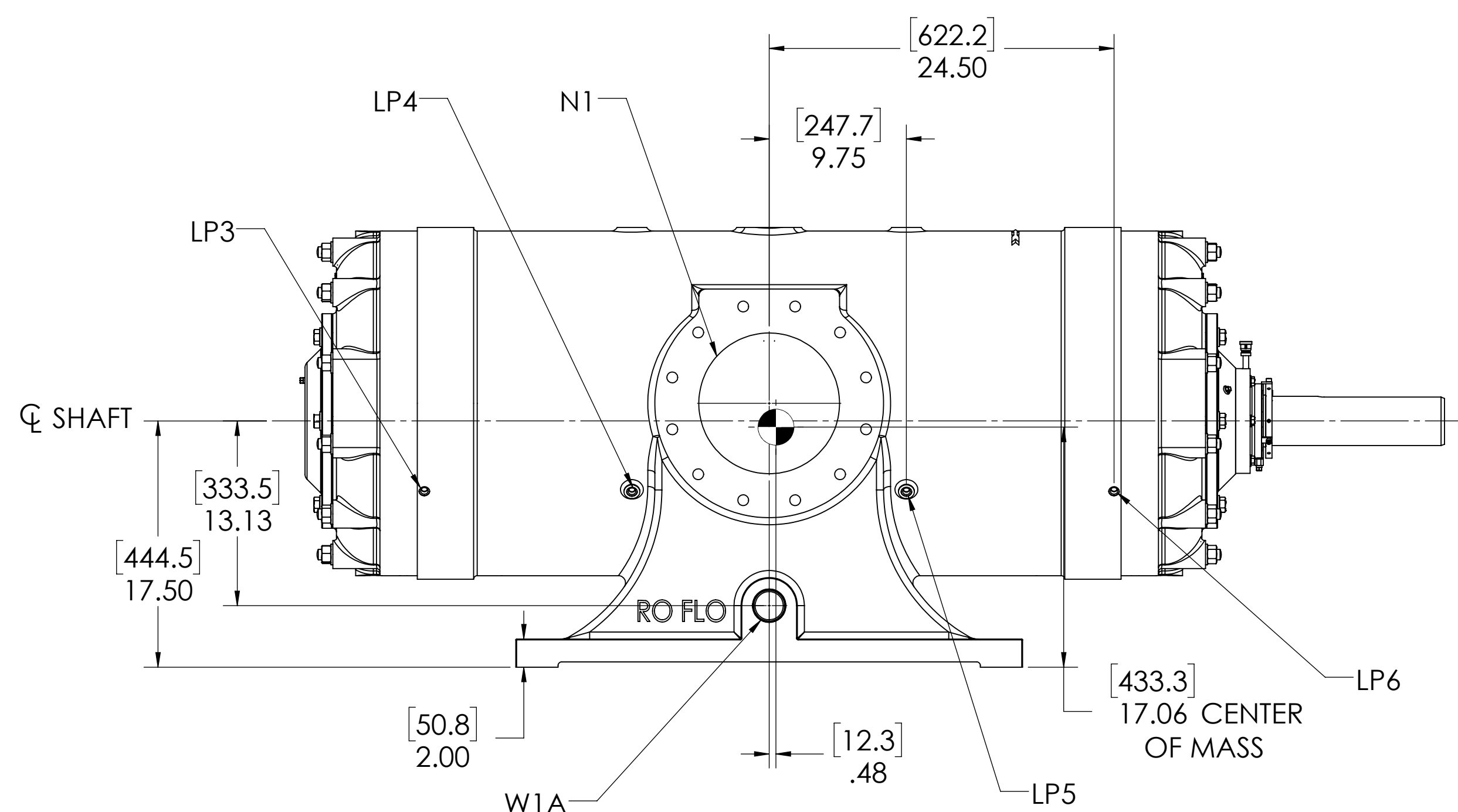
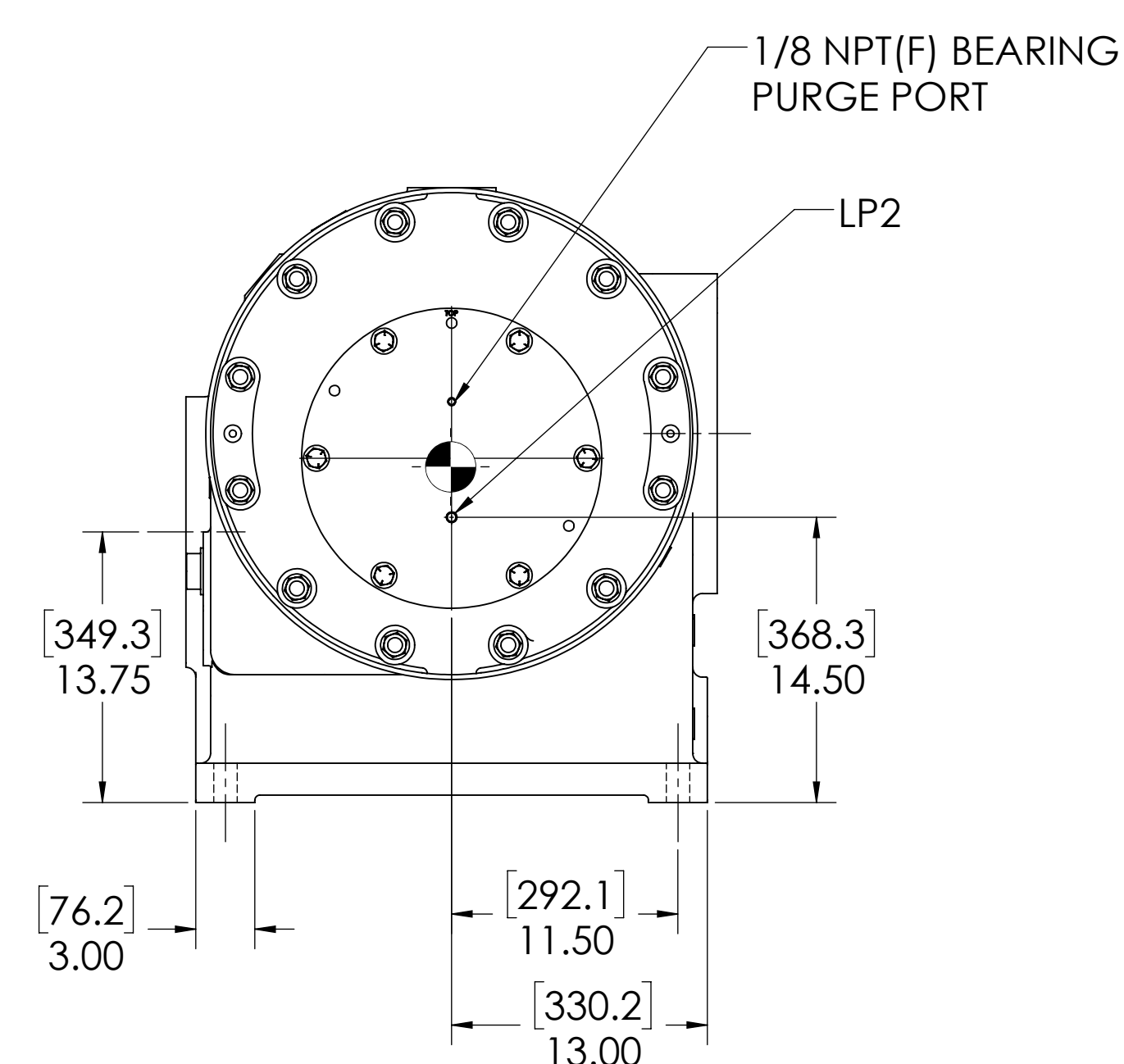
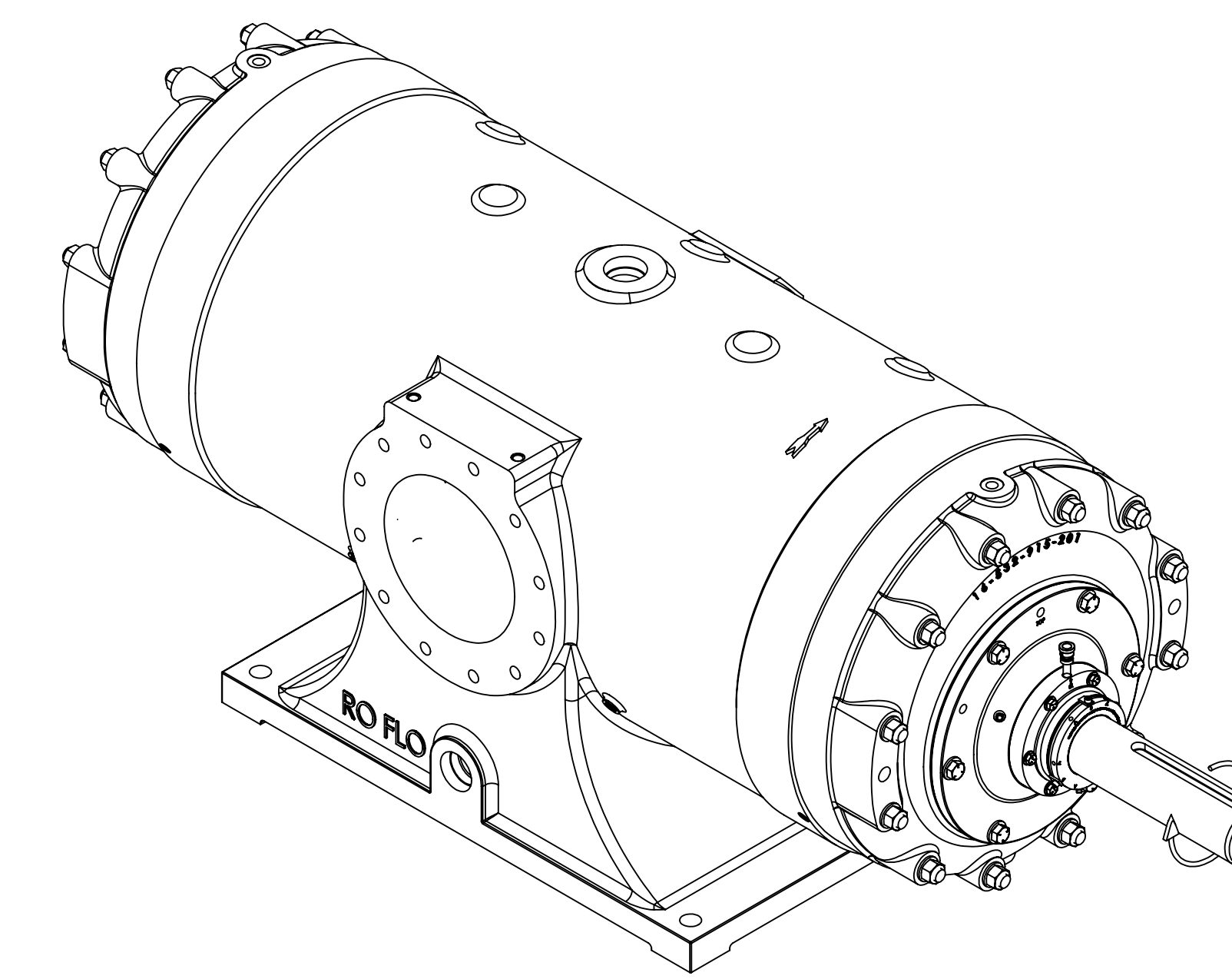
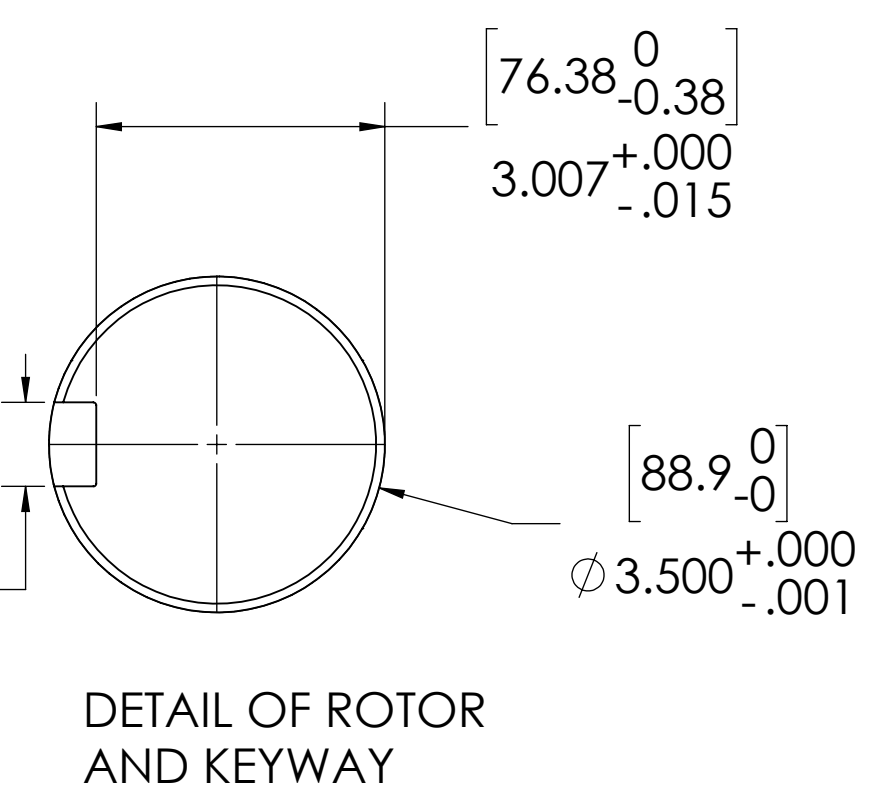

3/4-10 UNC - 2B  $\nabla$  .75 [19.1]  
THIS IS A LIFTING HOLE FOR CYLINDER HEAD (MAINTENANCE) ONLY.  
DO NOT USE THIS HOLE FOR LIFTING COMPRESSOR!

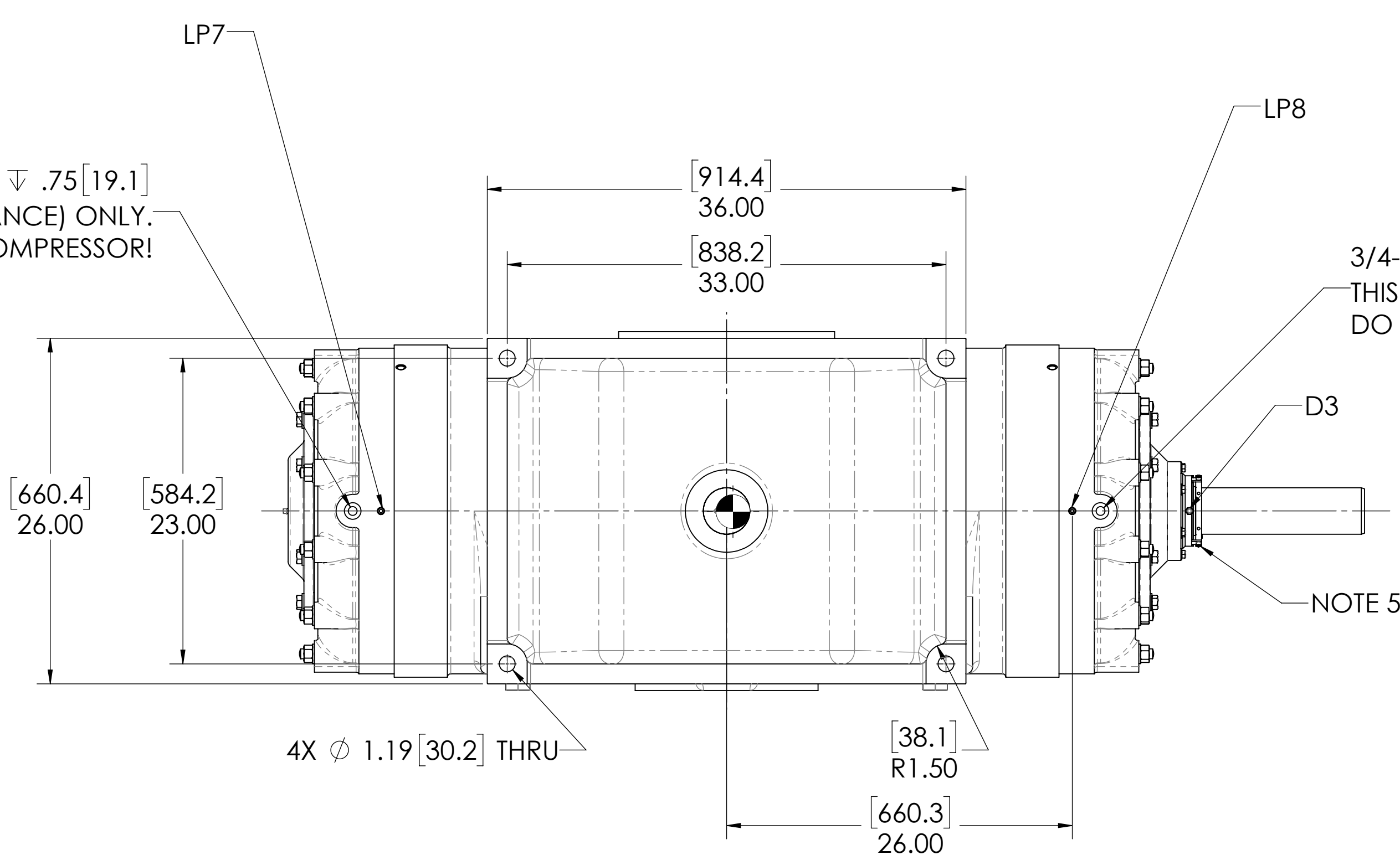

3/4-10 UNC - 2B  $\nabla$  .75 [19.1]  
THIS IS A LIFTING HOLE FOR CYLINDER HEAD (MAINTENANCE) ONLY.  
DO NOT USE THIS HOLE FOR LIFTING COMPRESSOR!

NOTES:

- CENTER OF MASS DIMENSIONS ARE APPROXIMATE
- EITHER WATER INLET MAY BE USED, DEPENDING UPON SYSTEM NEEDS
- WEIGHT IS APPROXIMATE
- THIS DRAWING IS DUAL DIMENSION. DIMENSIONS WITHOUT BRACKETS ARE IN INCHES, DIMENSIONS IN [BRACKETS] ARE IN MILLIMETERS.
- REMOVE (3) RED SEAL LOCKING TABS BEFORE OPERATION. RETAIN TABS AND SCREWS FOR SERVICE (TABS MUST BE INSTALLED BEFORE SEAL REMOVAL).

OIL CONNECTION POINTS SUMMARY		
(REFER TO MANUAL FOR FURTHER INFORMATION)		
DESCRIPTION	THREAD SIZE	QTY
LUBE QUILL(LQx)	1/4 NPT (F)	2
LUBE POINTS(LPx)	1/4 NPT (F)	8

NOZZLE CONNECTIONS		BOLT HOLE SIZE
N1	10" GAS SUCTION FLANGE (ANSI CLASS 150 FLAT FACE)	12 x 7/8-9 $\nabla$ 1.38
N2	8" GAS DISCHARGE FLANGE (ANSI CLASS 150 FLAT FACE)	8 x 3/4-10 $\nabla$ 1.12
W1A	2 NPT(F) WATER INLET (SEE NOTE 2)	N/A
W1B	2 NPT(F) WATER INLET (SEE NOTE 2)	N/A
W2	2 NPT(F) WATER OUTLET	N/A
D1	1/2 NPT (F) DRAIN HOLE	N/A
D2	1/2 NPT (F) DRAIN HOLE	N/A
D3	1/8 NPT (F) SEAL WEEPAGE DRAIN	N/A