

1/2-13 UNC - 2B ∇ .75 [19.1]
THIS IS A LIFTING HOLE FOR CYLINDER HEAD (MAINTENANCE) ONLY.
DO NOT USE THIS HOLE FOR LIFTING COMPRESSOR!

\square ϕ 1.25 [31.8] ∇ .05
FLAT CREATED FOR MOUNTING ACCELEROMETER
CENTERED ON LIFTING HOLE

1/4 NPT INSTRUMENTATION PORT

1/2-13 UNC - 2B ∇ .75 [19.1]
THIS IS A LIFTING HOLE FOR CYLINDER HEAD (MAINTENANCE) ONLY.
DO NOT USE THIS HOLE FOR LIFTING COMPRESSOR!

\square ϕ 1.25 [31.8] ∇ .05
FLAT CREATED FOR MOUNTING ACCELEROMETER
CENTERED ON LIFTING HOLE

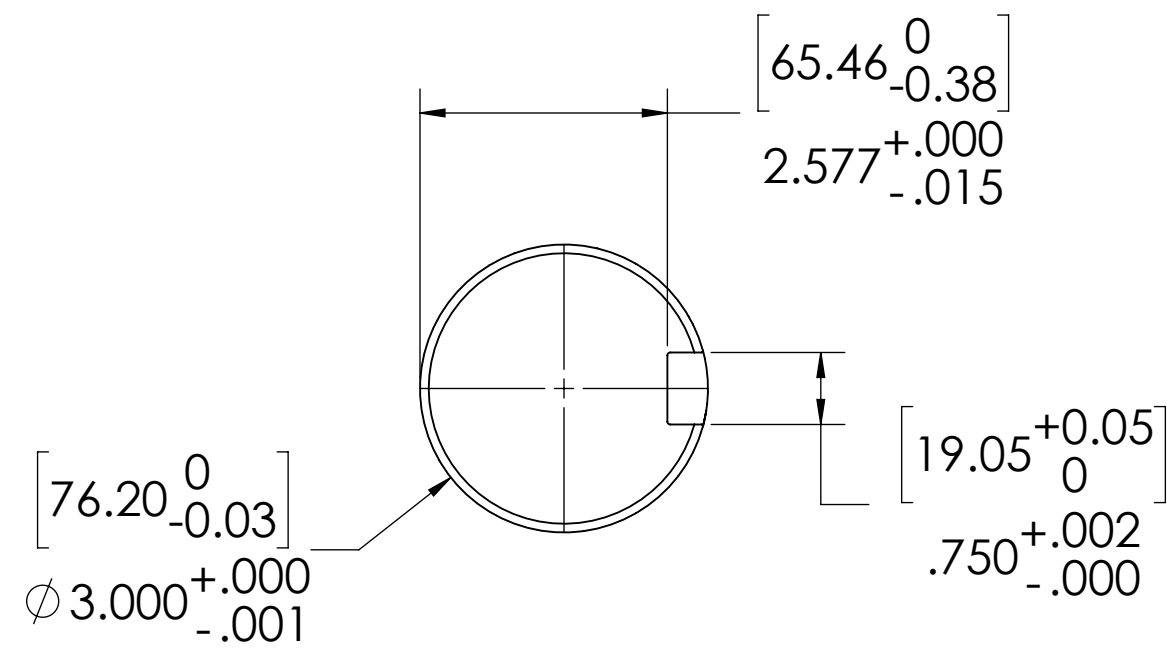
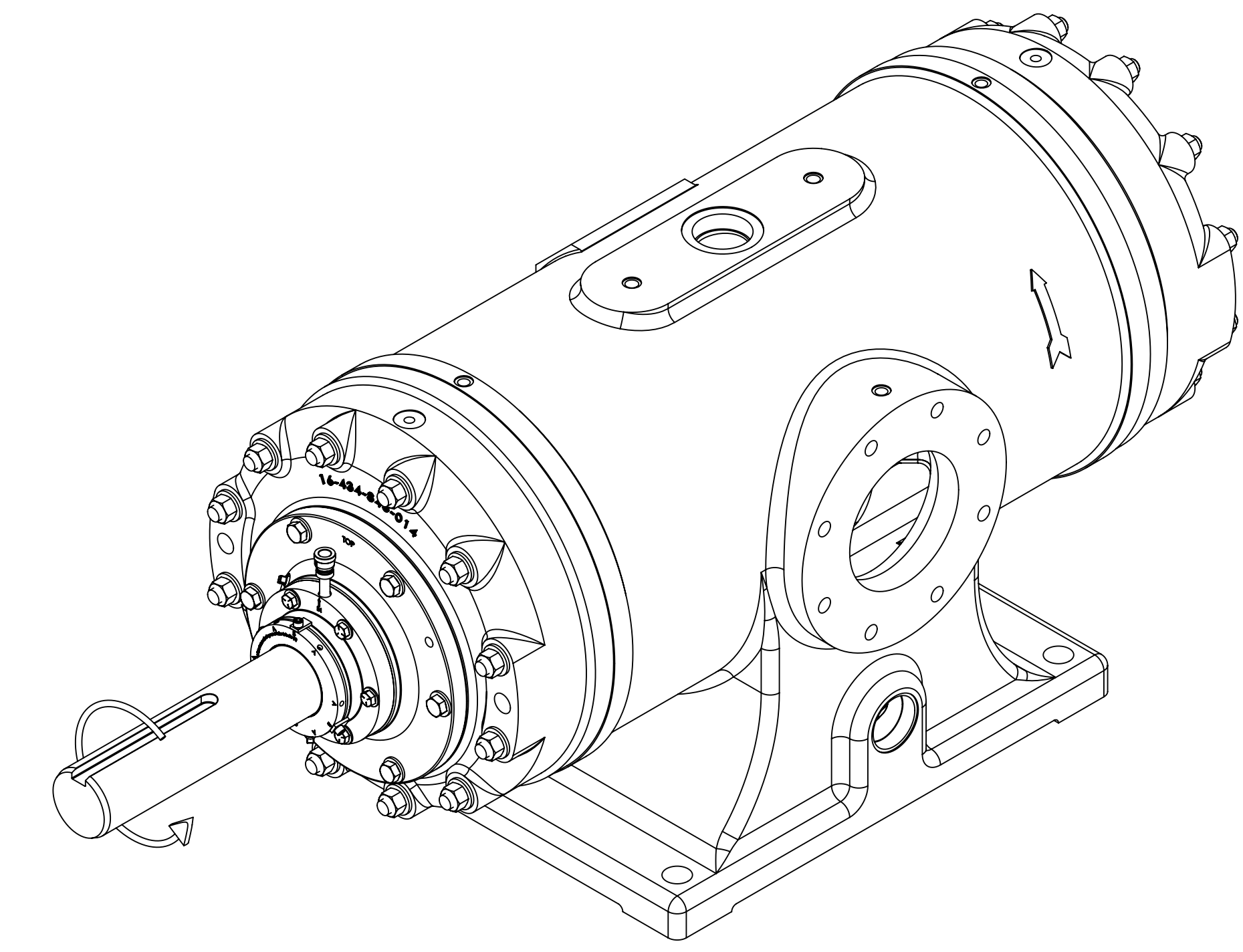

DETAIL OF ROTOR AND KEYWAY

[177.8]
7.00 CLEARANCE REQUIRED
TO REMOVE CYLINDER HEAD AND
SEAL ADAPTER

[603.3]
23.75 CLEARANCE REQUIRED
TO REMOVE ROTOR BLADES

[158.8]
6.25 CLEARANCE REQUIRED
TO REMOVE CYLINDER HEAD
AND END COVER

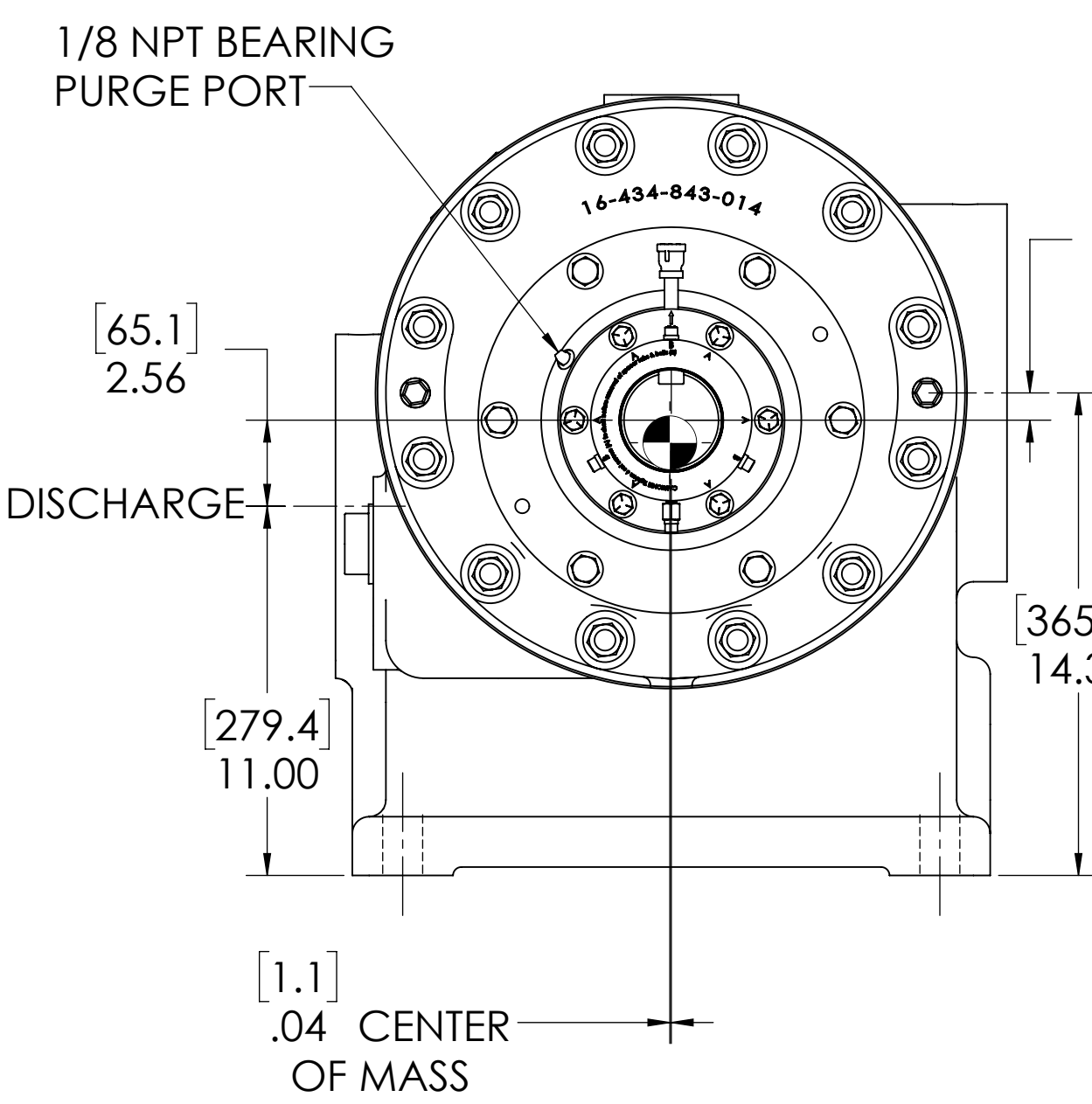

ϕ DISCHARGE

ϕ SUCTION
 ϕ SHAFT

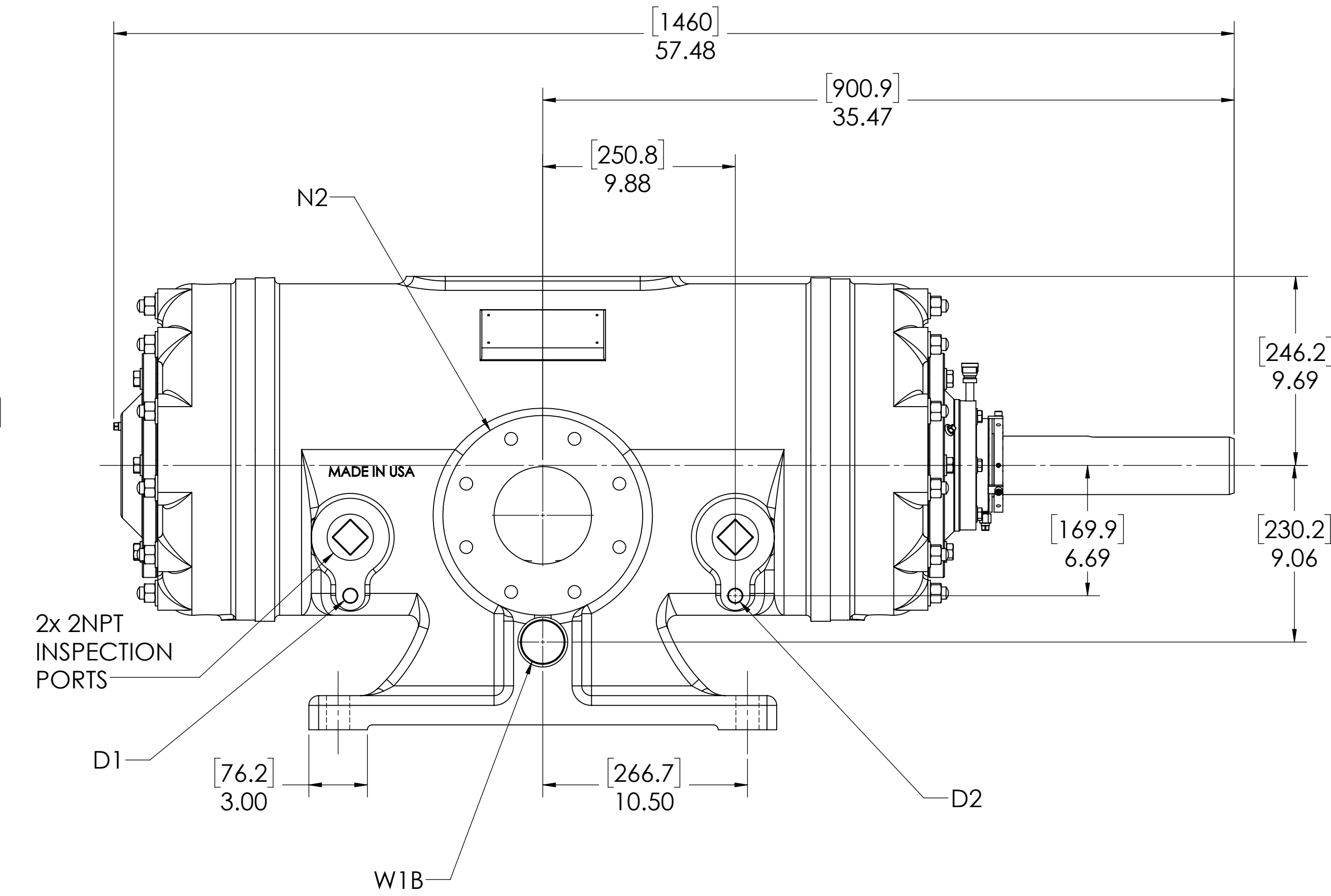
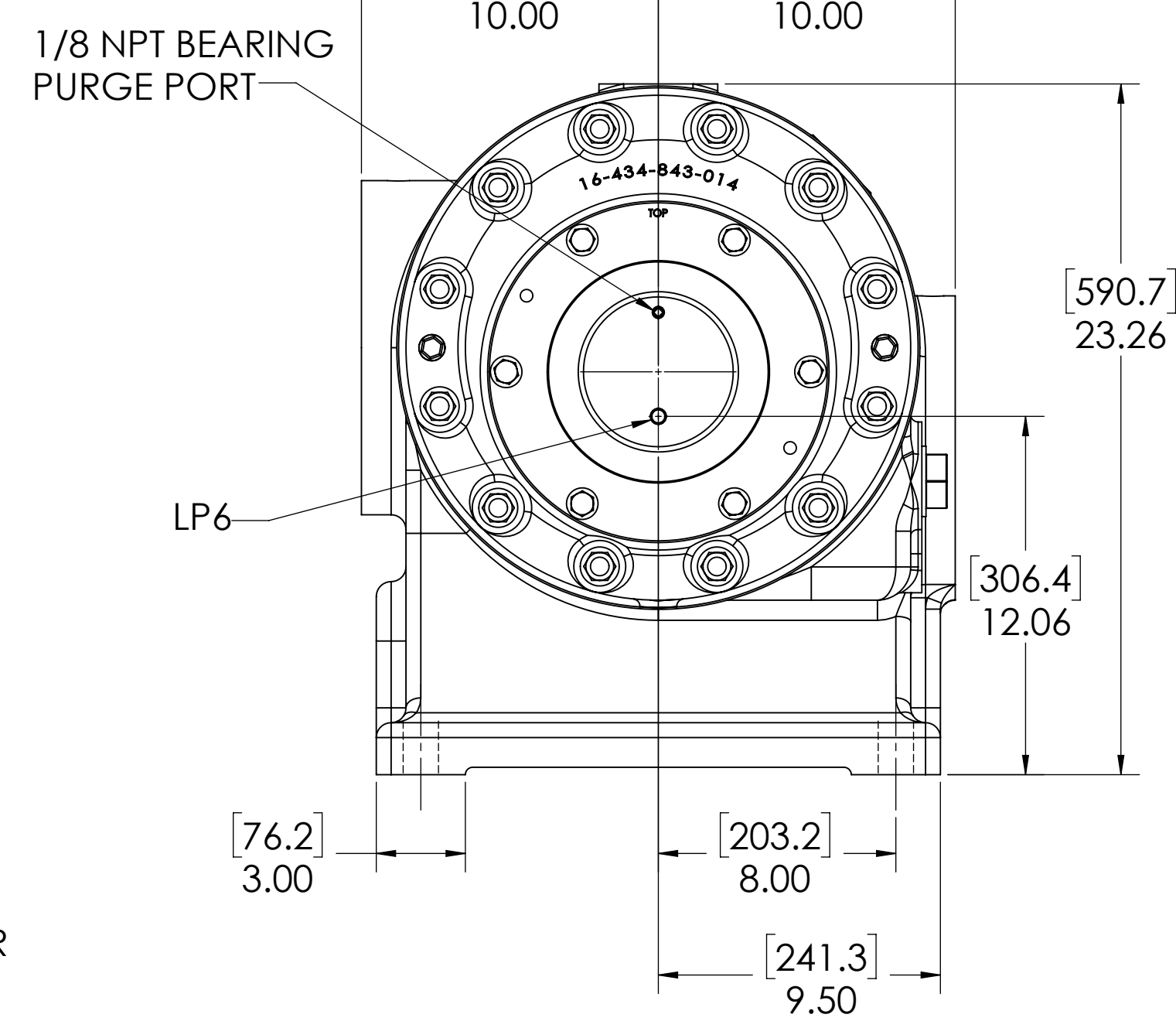
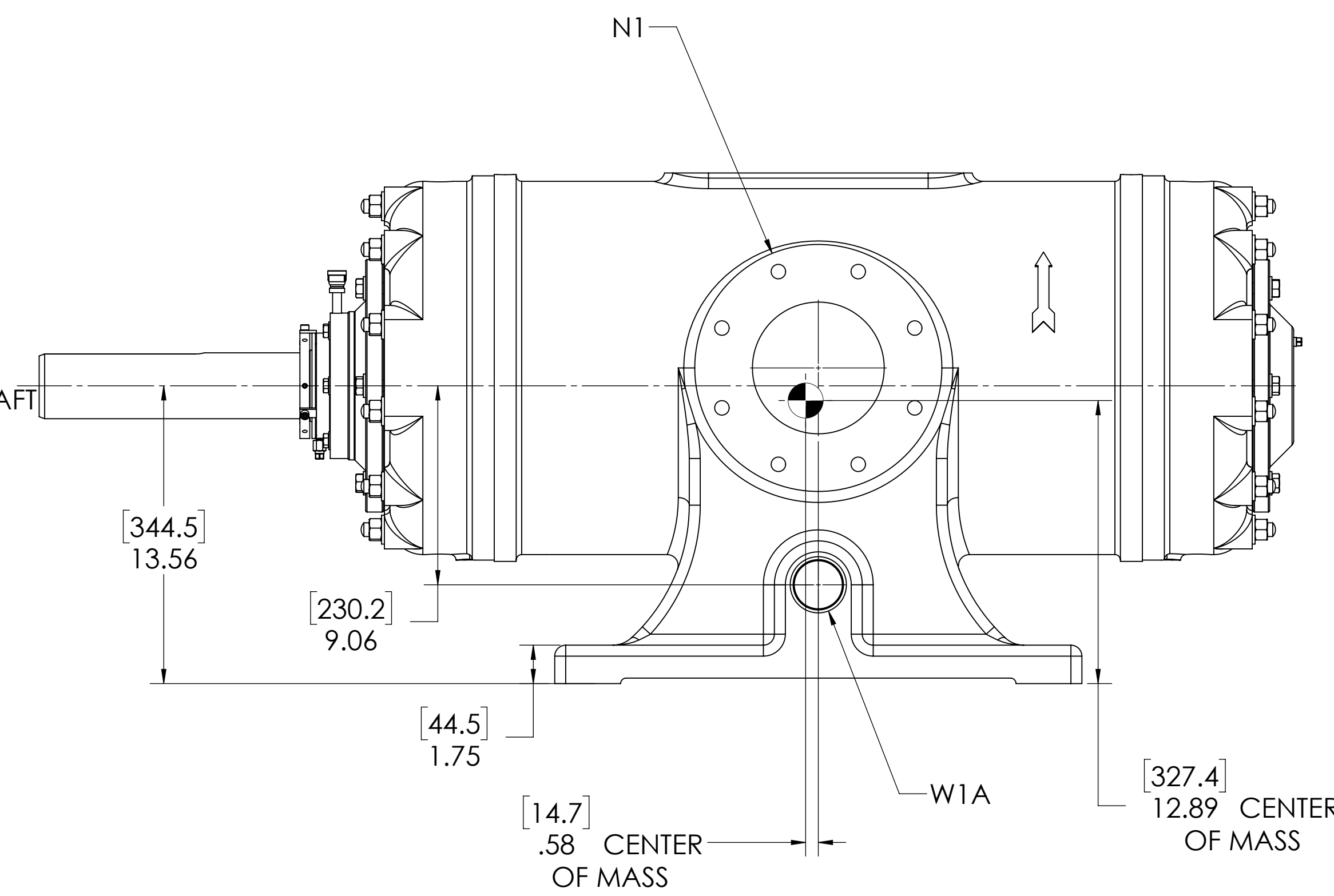

1/2-13 UNC - 2B ∇ .75 [19.1]
THIS IS A LIFTING HOLE FOR CYLINDER HEAD (MAINTENANCE) ONLY.
DO NOT USE THIS HOLE FOR LIFTING COMPRESSOR!

1/2-13 UNC - 2B ∇ .75 [19.1]
THIS IS A LIFTING HOLE FOR CYLINDER HEAD (MAINTENANCE) ONLY.
DO NOT USE THIS HOLE FOR LIFTING COMPRESSOR!

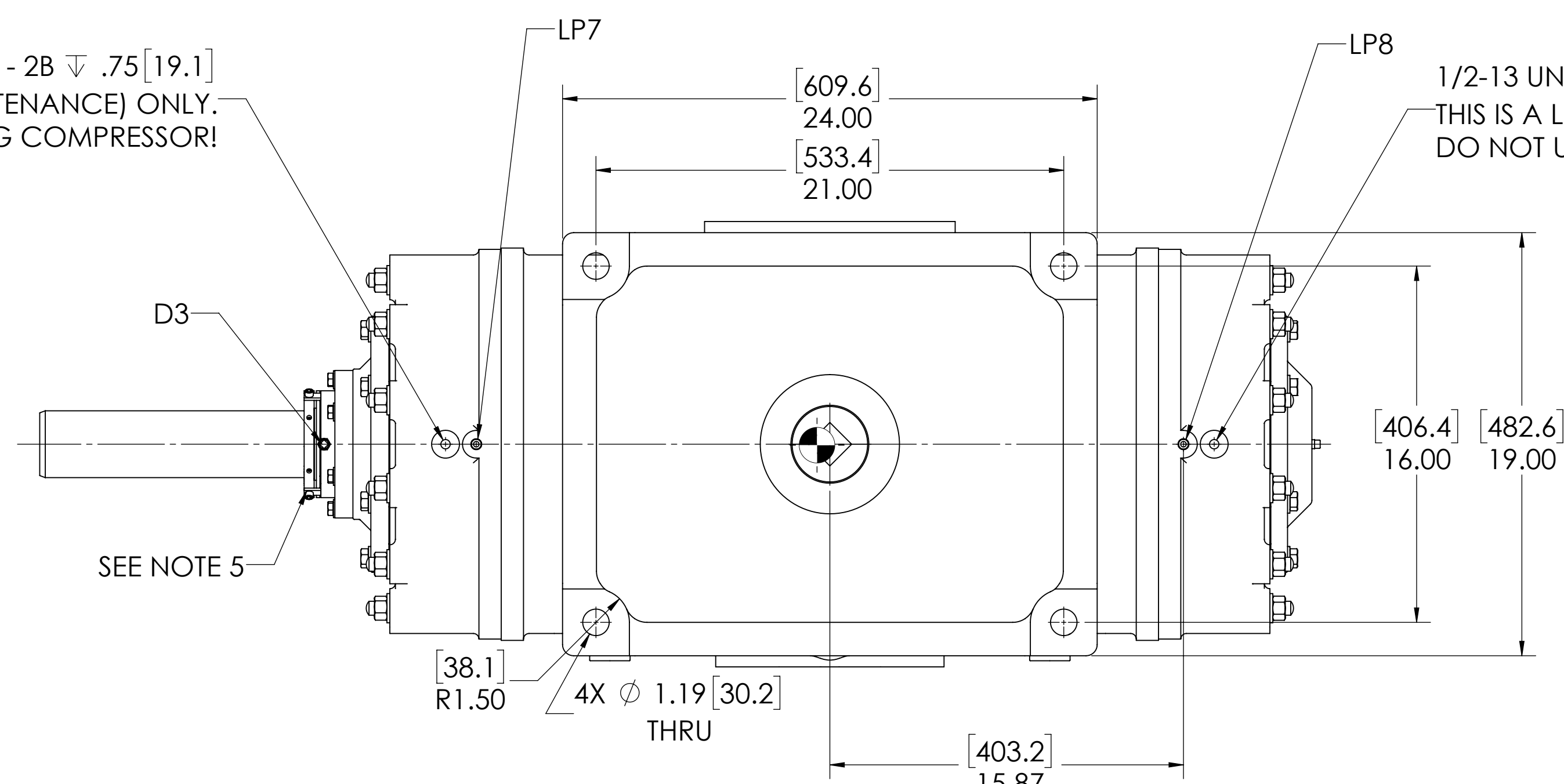

SEE NOTE 5

NOTES:

- CENTER OF MASS DIMENSIONS ARE APPROXIMATE
- EITHER WATER INLET MAY BE USED, DEPENDING UPON SYSTEM NEEDS
- WEIGHT IS APPROXIMATE
- THIS DRAWING IS DUAL DIMENSION. DIMENSIONS WITHOUT BRACKETS ARE IN INCHES, DIMENSIONS IN [BRACKETS] ARE IN MILLIMETERS.
- REMOVE (3) RED SEAL LOCKING TABS BEFORE OPERATION. RETAIN TABS AND SCREWS FOR SERVICE (TABS MUST BE INSTALLED BEFORE SEAL REMOVAL).

NOZZLE CONNECTIONS		BOLT HOLE SIZE
N1	6" GAS SUCTION FLANGE (ANSI CLASS 150 FLAT FACE)	8 x 3/4-10 ∇ 1.12
N2	5" GAS DISCHARGE FLANGE (ANSI CLASS 150 FLAT FACE)	8 x 3/4-10 ∇ 1.12
W1A	2 NPT(F) WATER INLET (SEE NOTE 2)	N/A
W1B	2 NPT(F) WATER INLET (SEE NOTE 2)	N/A
W2	2 NPT(F) WATER OUTLET	N/A
D1	1/2 NPT DRAIN HOLE	N/A
D2	1/2 NPT DRAIN HOLE	N/A
D3	1/8 NPT (F) SEAL WEEPAGE DRAIN	N/A

OIL CONNECTION POINTS SUMMARY (REFER TO MANUAL FOR FURTHER INFORMATION)		
DESCRIPTION	THREAD SIZE	QTY
LUBE QUILL (LQx)	1/4 NPT (F)	NONE
LUBE POINTS (LPx)	1/4 NPT (F)	8